

| CAMERA OPTIONS

C20

BASIC CAMERA



Pixel count	24.3 MP
Weight	300 g
CMOS Size	23.5mm × 15.6 mm
Minimal trigger time	0.7 s
Focal length of lens	35mm
Power supply	Dual redundant power supply
Attitude accuracy	< 0.02°
Communication	CAN

C50

OPTIONAL CAMERA

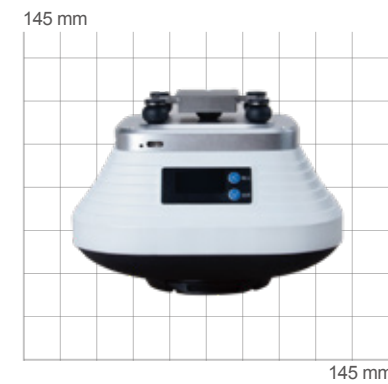

Size	145mm × 145 mm × 135 mm
Weight	800 g
Pixel count	120 MP
CMOS Size	35.9mm × 24 mm
Focal length of lens	25mm / 35mm (45°)
Power supply	Dual redundant power supply
Minimal trigger time	0.65 s
Trigger configuration	Remote configuration from ground station
CMOS Size	35.9mm × 24 mm
Storage	Expandable to 164 GB
Communication	CAN

E300 RTK DRONE

GENERAL SPECIFICATIONS

Drone type	Quadcopter with 4 propellers
Work mode	RTK / PPK
Take-off & landing	Automatic
Max flight time	60 min, without payload 50 min, with 1kg payload
Measurement radius	10 km
Assembly time	Start < 1 min / finish < 1 min

FLIGHT SPECIFICATIONS

Max level flight speed	20 m/s
Max climb speed	6 m/s
Max cruise speed	15 m/s
Max flight altitude	1000 m
Wind resistance	17.1 m/sec (level 7)

GNSS SPECIFICATIONS

GPS	L1 C/A, L2C, L2P, L5
BeiDou	B1, B2, B3
BeiDou Global	B1C, B2a
GLONASS	L1 C/A, L1P, L2 C/A, L2P
Galileo	E1, E5a, E5b, E5 AltBOC, E6
QZSS	L1C, L2, L5, L1C/A
RTK Accuracy	8 mm + 1 ppm Horizontal 15 mm + 1 ppm Vertical
PPK Accuracy	8 mm + 1 ppm Horizontal 15 mm + 1 ppm Vertical

PHYSICAL SPECIFICATIONS

Size	520 × 520 × 240 mm, unfolded 520 × 160 × 240 mm, folded
Working temperature	-30°C ~ 50°C
Weight without payload	1.8 kg
Payload	Up to 3 kg
Max take-off weight	6.5 kg
Size of box	580 × 360 × 200 mm

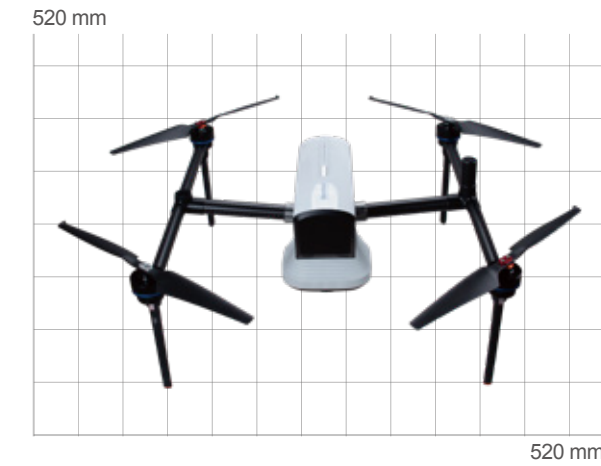

Size: 520 × 520 × 240 mm
Weight: 1.8 kg

Specifications subject to change without notice.



ComNav Technology Ltd.

Building 2, No. 618 Chengliu Middle Road, 201801 Shanghai, China
Tel : +86 21 64056796
Fax: +86 21 54309582
Email: sales@comnavtech.com
www.comnavtech.com



E300 RTK DRONE



Fast Assembly



Easy to Carry



60min Battery



High Accuracy

| PRODUCT COMPONENTS



- 01 | Landing Gears
- 02 | GNSS Helix Antenna
- 03 | Detachable Drone Blades
- 04 | Rugged Body
- 05 | Dustproof Motor
- 06 | Folding Structure
- 07 | Camera Gimbal
- 08 | Battery
- 09 | Transport Case



| FEATURES



PROFESSIONAL PAYLOAD

Detachable design and multiple payload options for your various purposes.



SAFETY & EFFICIENCY

Redundancy design on the key modules ensure the safety. 60min long working time for higher efficiency.

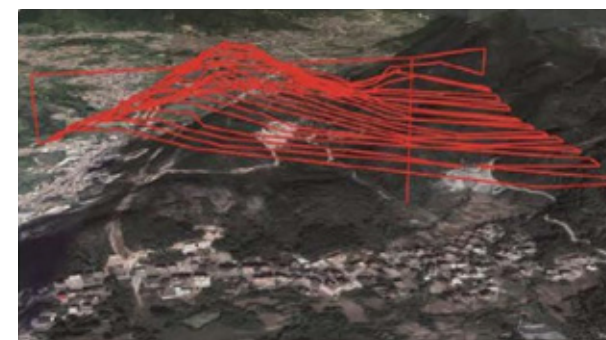

TERRAIN AWARENESS

Based on intelligent recognition algorithms, ensuring the consistency of image resolution.

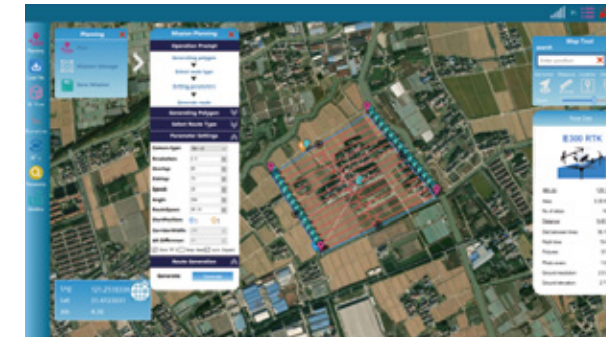

INTELLIGENT ROUTE PLANNING

Support automatic route generation, manual route editing or KML file import.



FREE OF GCPS

Embedded with high precision GNSS module, providing centimeter accuracy without GCPS.



SMART BATTERY DESIGN

Automatic control of dynamic battery charging and discharging, voltage load balancing and prolonging battery life.

| FLIGHT CONTROL SOFTWARE

Partnered flight control software equipped with clear interface, easy workflow, powerful flight control capability, which can completely satisfy the the requirements of high-efficiency, high-quality and high-precision aerial survey operations.

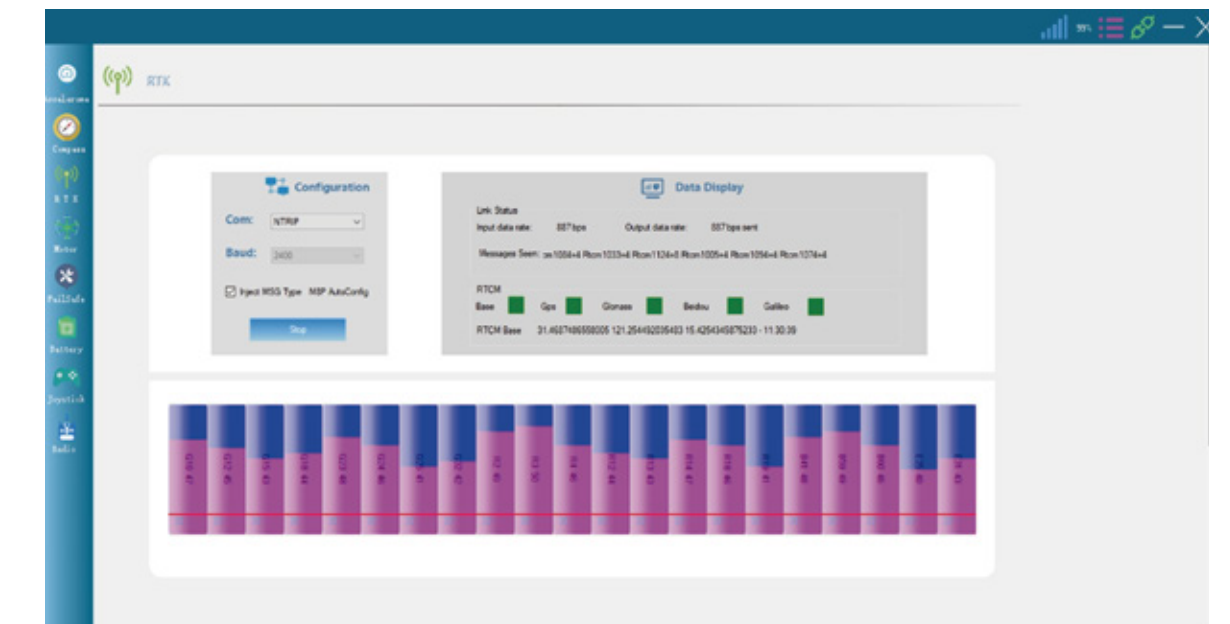

- ▶ Clear interface and operation guidance of flight route planning, making it convenient and fast to plan a flight task.
- ▶ Perform automated flight missions after connecting the drone, human operation during the whole flight only includes execute, pause and end the task.
- ▶ Support manual control of the flight attitude via computer keyboard. Click the "Pause" button to enter the manual control mode in special circumstances.
- ▶ Wait for the next instruction at a safe altitude when returning from the flight mission and landing, the flight can only be continued under safe conditions.