



# 司南导航

Product Specification / 产品规范

## K726 OEM Board

## K726 OEM 板卡

2017-03-23

## REVISION HISTORY / 修订历史

REVISION / 版本	MODIFICATION / 更改	DATE / 日期
1.0	New Release / 新发	2017-03-23

## TABLE OF CONTENTS

<b>I. Introduction / 简介</b> .....	<b>1</b>
<b>II. Specification of K726 OEM Board / K726 OEM 板卡技术规范</b> .....	<b>1</b>
<b>III. Dimension / 尺寸</b> .....	<b>4</b>
<b>IV. Pin Arrangement and Definition / 引脚标识和定义</b> .....	<b>5</b>
<b>V. Application Connection Example / 应用连接示例</b> .....	<b>9</b>

### FIGURE & TABLE 图表

Figure 1. K726 Dimension View .....	5
Figure 2. K726 Pin Assignment Schematic.....	10
Figure 3. Connections between RS232 COM1, 2, 3 of K726 and Some Other Devices with an UART .....	11
Table 1. K726 Specification.....	1
Table 2. Pin Definition of K726 24Pin Main Connector .....	5

## I. INTRODUCTION / 简介

ComNav K726 OEM board is a high precision positioning and orientation GNSS OEM board based on a self-developed ASIC baseband chip (SNB1008). K726 is mainly designed and used for UAV and some other new industries with high precision positioning and orientation requirements.

上海司南 K726 OEM 板卡是一款基于自主研发 ASIC 基带芯片(SNB1008)的多系统高精度定位、定向板卡。主要适用于无人机等新行业对高精度定位和姿态测量的应用需求。

## II. SPECIFICATION OF K726 OEM BOARD / K726 OEM 板卡技术规范

Following table presents the detailed specification of ComNav K726 OEM board. Specific technical characteristics are listed with its physical interface and electrical parameters.

下表中为司南 K726 OEM 板卡的详细规范。同时，还列出了该板卡的各项技术性能，以及它的物理接口和电气接口参数。

Table 1. K726 Specification

K726 SPECIFICATION / K726 规范			
GNSS Signals GNSS 信号	Positioning 定位	GPS L1, L2	14 GPS satellite tracked at the same time 可同时跟踪 14 颗 GPS 卫星
		BDS B1, B2	14 BDS satellite tracked at the same time 可同时跟踪 14 颗 BDS 卫星
		GLONASS G1, G2	14 GLONASS satellites tracked at the same time 可同时跟踪 14 颗 GLONASS 卫星
	Orientation 定向	GPS L1, L2	14 GPS satellite tracked at the same time 可同时跟踪 14 颗 GPS 卫星
		BDS B1, B2	14 BDS satellite tracked at the same time 可同时跟踪 14 颗 BDS 卫星
		GLONASS G1, G2	14 GLONASS satellites tracked at the same time 可同时跟踪 14 颗 GLONASS 卫星
Time to First Fix	Cold Start 冷启动	< 50s	

K726 SPECIFICATION / K726 规范		
首次定位时间	Warm Start 温启动	< 30s
	Hot Start (with RTC) 热启动 (使用 RTC)	< 15s
Reacquisition 信号重捕	L1 or B1	< 1.5s (fast mode) (快速) < 3.0s (normal mode) (普通)
Measurement Precision 测量准确度	Pseudorange Precision 伪距精度	GPS: L1=10cm, L2=10cm BDS: B1=10cm, B2=10cm GLONASS: G1=10cm, G2=10cm
	Carrier Phase Precision 载波相位精度	GPS: L1=0.5mm, L2=1.0mm BDS: B1=0.5mm, B2=0.5mm GLONASS: G1=1.0mm, G2=1.0mm
Accuracy 精度	Timing Accuracy 授时精度	20ns
	SPP Accuracy 标准单点定位精度	Single-frequency 单频: H≤3m, V≤5m (1σ, PDOP≤4) Dual-frequency 双频: H≤1.5m, V≤3m (1σ, PDOP≤4)
	Static Differential Accuracy (Supported by Compass Solution) 静态差分精度 (Compass Solution 软件支持)	H: $\pm(2.5+1\times 10^{-6}\times D)$ mm V: $\pm(5.0+1\times 10^{-6}\times D)$ mm
Attitude Accuracy 测姿精度	Heading Accuracy 航向角精度	$(0.2/R)^\circ$ , R is baseline length in meter. R 为基线距离, 单位为米。
	Roll or Pitch Accuracy 横滚或俯仰角	$(0.4/R)^\circ$ , R is baseline length in meter. R 为基线距离, 单位为米
RTK	RTK Initiation Time RTK 初始化时间	< 10s (baseline<10km, 基线长小于 10km)
	Initiation Reliability 初始化置信度	> 99.9%

K726 SPECIFICATION / K726 规范		
	Dynamic Differential Accuracy 动态差分精度	H: $\pm(10+1\times 10^{-6}\times D)$ mm V: $\pm(20+1\times 10^{-6}\times D)$ mm
Data Rates 数据速率	Measurements & PVT 观测量&PVT	1Hz, 2Hz, 5Hz, 10Hz, 20Hz, 50Hz (Max)
	RTK: Positioning & Heading RTK: 定位&定向	1Hz, 2Hz, 5Hz, 10Hz, 20Hz, 50Hz (Max)
Electrical 电气特性	Voltage 供电电压	+3.3V ~ +5.5V $\pm$ 5%VDC
	Power Consumption 功耗	1.96W
Environmental 环境要求	Operating Temperature 工作温度	-40°C — +85°C
	Storage Temperature 储存温度	-55°C — +95°C
Data Formats 输出数据格式	NMEA-0183	GPGGA, GPGGARTK, GPGSV, GPGLL, GPGSA, GPGST, GPHDT, GPRMC, GPVTG, GPZDA etc.
	ComNav Binary 司南二进制格式	ComNav Self-Defined 司南自定义
	CMR (GPS)	CMROBS, CMRREF
	RTCM2.X	RTCM1, RTCM3, RTCM9, RTCM1819, RTCM31, RTCM59
	RTCM3.0	1004, 1005, 1006, 1007, 1008, 1011, 1012, 1104, 1033
	RTCM3.2 MSM4 & MSM5	1074, 1084, 1124, 1075, 1085, 1125
Antenna Interface 天线接口	Antenna Connector 天线连接器	50 $\Omega$ , MMCX female $\times$ 2 (MMCX 双母头)
	LNA Power 天线供电电压	+5V $\pm$ 2%VDC @ 0-100mA Internal: supplied by card through center conductor of RF connector

K726 SPECIFICATION / K726 规范		
		内部供电：由板卡的射频连接器的中心导体供电
	LNA Gain 天线增益要求	20 ~ 35dB (suggested 建议)
Hardware Interface 硬件接口		2×12 pin male connector, pin pitch 2mm 2×12 针公头，针脚间距 2mm
Physical 物理参数	Size 尺寸	46mm×71mm×9mm with connectors 含接头
	Weight 重量	<27.2 grams 克

### III. DIMENSION / 尺寸

In this section, three-side views and the dimension of K726 are provided for customers' further hardware design and installation.

本节提供了 K726 的三视图和对应的物理尺寸，便于用户进一步系统硬件设计和安装。

**Top View/顶视图**

**Side View/侧视图**

**Bottom View/底视图**

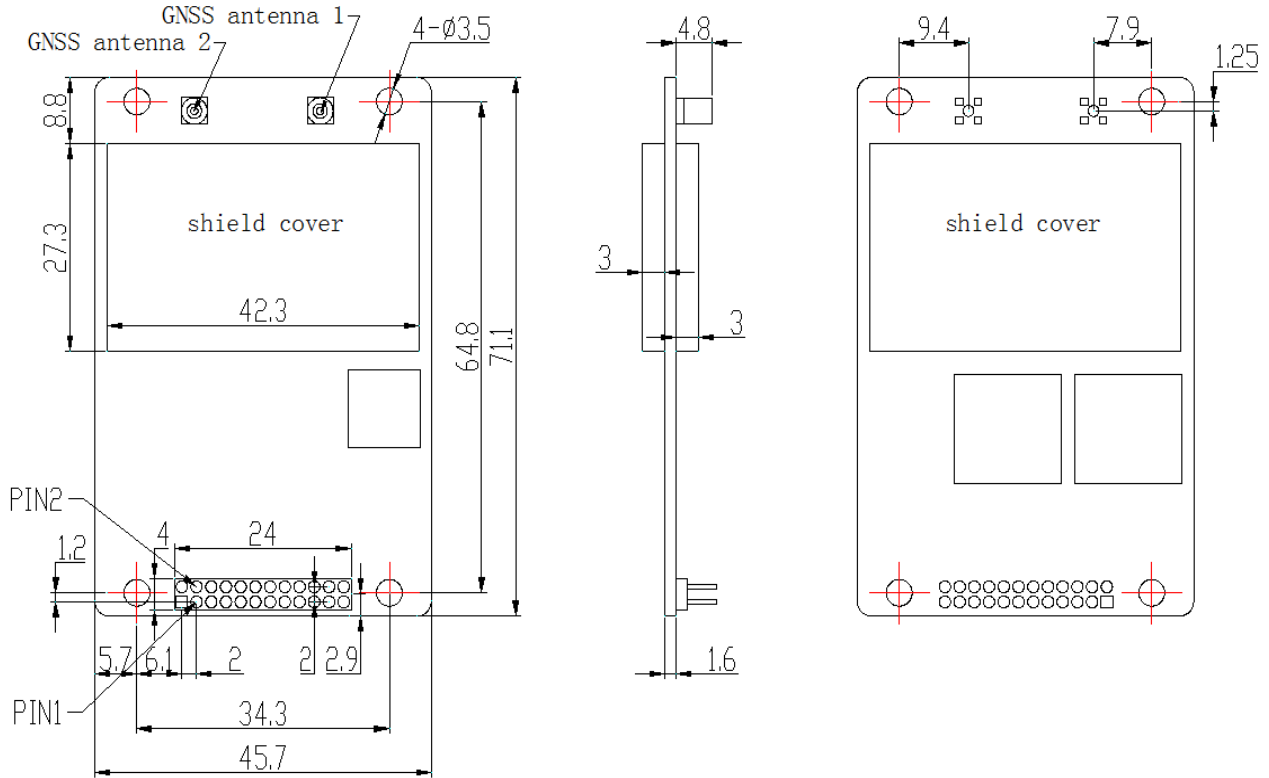

Figure 1. K726 Dimension View

图 1. K726 三视图

**TIPS 提示:**

The copy of AutoCAD dwg files as shown in Figure 1, can be obtained from the attachment of this document, which can be imported into EDA tools directly facilitating your system hardware design.

该文档的附件包含上面的 AutoCAD dwg 文件，可直接导入 EDA 软件用于系统硬件设计。

## IV. PIN ARRANGEMENT AND DEFINITION / 引脚标识和定义

K726 has one 24-Pin connectors (12 Pin, 2mm Dual Row vertical T/H HDR).

K726 板卡包括 24 针接头（针脚间距 2mm，双排）。

Table 2. Pin Definition of K726 24Pin Main Connector

PIN	SIGNAL	TYPE	DESCRIPTION
1	SPI1_CLK	O	SPI clock signal SPI 总线时钟信号
2	SPI1_CS0	O	SPI CS signal SPI 总线片选信号

©2017, ComNav Technology Ltd. All rights reserved. SinoGNSS is the trade mark of ComNav Technology Ltd., registered in People's Republic of China. All other trademarks are the property of their respective owners.



PIN	SIGNAL	TYPE	DESCRIPTION
3	LNA_PWR	PWR	antenna power supply 天线供电
4	3V3	PWR	DC power supply for card 板卡供电电源
5	USB_D-	IO	USB device interface data (-) USB 数据信号 (-)
6	USB_D+/RXD3	MUL	multiplexed pin: USB device interface data (+) / UART3 RX default: USB_D+ 复用关键: USB 数据信号 (+) / UART3 RX 默认状态: USB_D+
7	RST_SYS	I	system reset 系统复位
8	VARF/CAN1RX	MUL	multiplexed pin: 10MHz square wave output / CAN1 input default: CAN1RX 复用管脚: 10MHz 方波输出 / CAN1 数据接收信号 默认状态: CAN1RX
9	EVENT2/CAN1TX	MUL	multiplexed pin: external event input / CAN1 output default: CAN1TX 复用管脚: 外部事件输入 / CAN1 数据发送信号 默认状态: CAN1TX
10	CAN2RX/LED_RTK	MUL	multiplexed pin: CAN input / RTK data LED indicator default: CAN2RX CAN2 数据接收信号 / RTK 数据指示灯 默认状态: CAN2RX
11	EVENT1/TXD3	MUL	multiplexed pin: external event input / UART3 TX default: EVENT1 复用管脚: 外部事件输入 / UART3 TX 默认状态: EVENT1
12	GND	GND	ground reference 系统接地
13	TXD1	O	transmitted data for COM1 output COM1 串口输出
14	RXD1	I	received data for COM1 input COM1 串口输入
15	GND	GND	ground reference 系统接地
16	TXD2	O	transmitted data for COM2 output COM2 串口输出
17	RXD2	I	received data for COM2 input COM2 串口输入
18	GND	GND	ground reference 系统接地

PIN	SIGNAL	TYPE	DESCRIPTION
19	PV	O	valid position solution indicator 位置有效指示信号
20	GND	GND	ground reference 系统接地
21	PPS	O	pulse per second 秒脉冲
22	CAN2TX/LED_SAT	MUL	multiplexed pin: CAN2 output / 复用管脚: CAN2 数据发送信号/ tracked satellite number indicator 跟踪卫星数量指示灯 default: CAN2TX 默认状态: CAN2TX
23	SPI1_MISO	I	SPI1 master in slave out SPI1 主输入从输出信号
24	SPI1_MOSI	O	SPI1 master out slave in SPI1 主输出从输入信号

### REMARKS / 说明:

1. Twenty pins in the middle of the K726, namely pins 3 to 22, are compatible with the international mainstream boards. Four pins which are SPI1\_CLK, SPI1\_CS0, SPI1\_MISO and SPI1\_MOSI at the ends could not be used and wouldn't affect the normal work of the board.

K726中间的20个针脚，即3-22针脚，与国际主流板卡兼容。两端的4个针脚SPI1\_CLK、SPI1\_CS0、SPI1\_MISO、SPI1\_MOSI可不使用，不影响板卡正常工作。

2. CAN interfaces are not available now.

CAN接口目前不可用。

3. Electronic characteristic/电气特性

RTK\_LED, SAT\_LED, COM1\_Tx, COM1\_Rx, COM2\_Tx, COM2\_Rx, COM3\_Tx, COM3\_Rx, CAN1\_RX, CAN1\_TX, CAN2\_TX, CAN2\_RX, RESETIN, SPI\_CLK, SPI\_CS, SPI\_MOSI and SPI\_MISO are LVCMOS 3.3V.

RTK\_LED、SAT\_LED、COM1\_Tx、COM1\_Rx、COM2\_Tx、COM2\_Rx、COM3\_Tx、COM3\_Rx、CAN1\_RX、CAN1\_TX、CAN2\_TX、CAN2\_RX、RESETIN、SPI\_CLK、SPI\_CS、SPI\_MOSI以及SPI\_MISO为LVCMOS 3.3V电气标准。

### LVCMOS 3.3V电气标准

Symbols 符号	Description 描述	Min 最小	Max 最大
V <sub>IH</sub>	Input high voltage 输入高电压	2V	3.6V
V <sub>IL</sub>	Input low voltage 输入低电压	-0.3V	0.8V
V <sub>OH</sub>	High-level output voltage 高电平输出电压	2.9V	--
V <sub>OL</sub>	Low-level output voltage 低电平输出电压	--	0.4V
I <sub>OH</sub>	Sourcing current 拉电流	8mA	
I <sub>OL</sub>	Sinking current 灌电流	8mA	

4. PPS, EVENT, EVENT2 and VARF are LVTTTL3.3V. All these signals are compatible with LVCMOS/LVTTTL 3.3V.

PPS、EVENT、EVENT2和VARF为LVTTTL3.3 V电平,所有这些信号均兼容LVCMOS/LVTTTL 3.3V。

Symbols/符号	Description/描述	Min/最小	Max/最大
V <sub>IH</sub>	Input high voltage 输入高电压	2.0V	---
V <sub>IL</sub>	Input low voltage 输入低电压	-0.3V	0.8V
V <sub>OH</sub>	High-level output voltage 高电平输出电压	2.4V	---
V <sub>OL</sub>	Low-level output voltage 低电平输出电压	---	0.4V
I <sub>OH</sub>	Sourcing current 拉电流	8mA	
I <sub>OL</sub>	Sinking current 灌电流	8mA	

5. Absolute maximum rating is -0.3V ~ 3.6V of following signals:

所能承受电压的最大值范围是-0.3V ~ 3.6V的信号如下:

RTK\_LED, SAT\_LED, COM1\_Rx, COM1\_Tx, COM2\_Rx, COM2\_Tx, COM3\_Rx, COM3\_Tx, EVENT, EVENT2, PPS, VARF, RESETIN, CAN1\_Rx, CAN1\_Tx, CAN2\_Rx, CAN2\_Tx, SPI\_CLK, SPI\_CS, PI\_MOSI, SPI\_MISO.

6. CAN is LVTTTL 3.3V, so a transceiver is needed for normal use.

CAN是LVTTTL 3.3V, 所以需要一个收发器才能正常使用。

7. USB

K726 USB has a built-in controller. The unit supports USB 2.0 device configuration at low/full/high speed configuration. The port has ESD protection, but a USB 2.0 compliant common mode choke should be added near the USB connector if better EMI performance is needed.

VBUS is only used for USB cable plug-in detection as an input IO. You can connect VBUS directly to USB connector.

K726使用内建控制器，可配置为低速/全速/高速USB设备。接口有做ESD防护，如果需要获得较好的EMC表现，可以在接插件处增加安装共模电感。

VBUS用作USB线缆接入检测，直接将VBUS引脚连接到USB接插件的VBUS引脚。

## 8. VCC

It is main power supply, which voltage range is 3.3VDC ~ 5.5V DC.

The requirement for voltage ripple and spike is less than 100mV.

主供电电源，电压范围：3.3V ~ 5.5V（直流）。电压纹波和尖峰脉冲要求小于100mV。

## 9. SYS\_RST

It is low active and can be used to reset the whole OEM board. It is 3.0V compatible.

低电平有效，可用于复位整个OEM板。

## 10. RTK\_LED / SAT\_LED

SAT\_LED is used to indicate the satellite number. RTK\_LED indicates that RTK is undergoing. Both RTK\_LED and SAT\_LED are all high active. External LED driver is needed for normal use.

RTK\_LED闪烁指示接收到基准站的数据，SAT\_LED指示卫星数量，一次连续闪烁的次数表示当前搜到卫星的数量。RTK\_LED与SAT\_LED均为高电平驱动LED，需要外加LED驱动。

# V. APPLICATION CONNECTION EXAMPLE / 应用连接示例

In this section, an application connection example of K726 OEM board is presented via specific schematic diagrams. Per the instruction of these diagrams, you could easily build the communication circuits between K726 OEM board and other terminals such as PC, GPRS or Bluetooth module, and some other devices with an UART.

本部分以具体电路的形式提供一个 K726 板卡应用连接示例。参照下面的图示，您可以很方便建立 K726 板卡和其他终端（如 PC、GPRS 模块、蓝牙模块或其他带有 UART 的设备）之间的通讯电路。

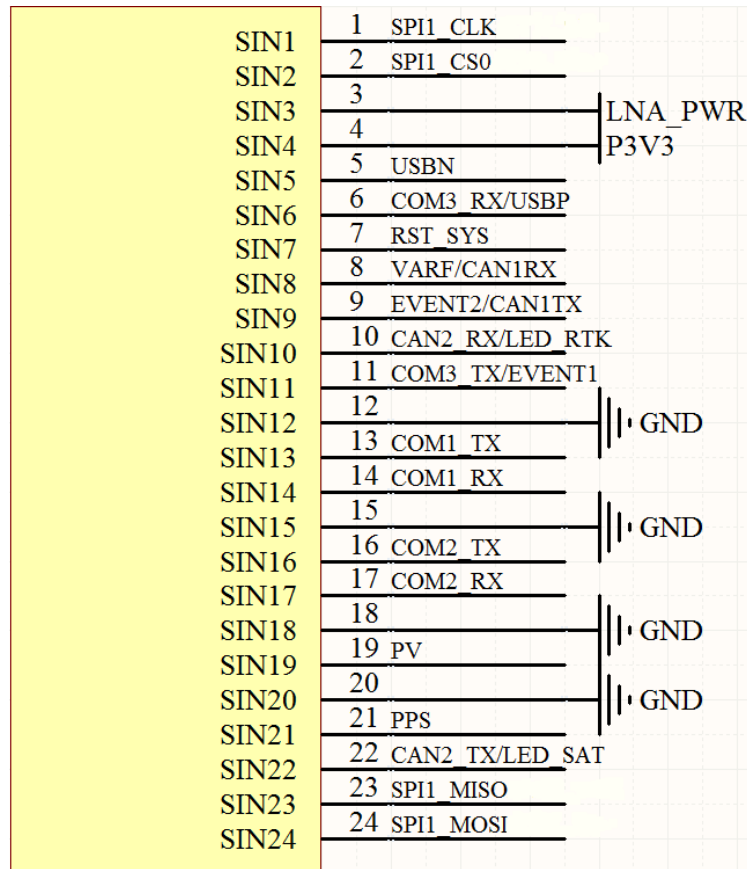

Figure 2. K726 Pin Assignment Schematic

图 2. K726 引脚分配及外接电路示意

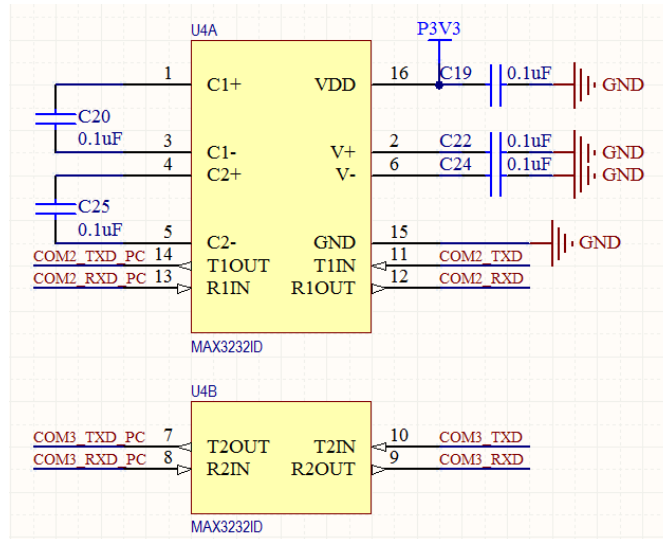

Figure 3. Connections between RS232 COM1, 2, 3 of K726 and Some Other Devices with an UART

图 3. K726 RS232 COM1、COM2、COM3 与其他使用 UART 接口的设备之间的连接示意